

GR-15E007DJ: E-mode GaN Power Transistor

Description

GR-15E007DJ is an enhancement mode GaN on Silicon power transistor. 15E007DJ provides high current and high operating speed which is suitable for DC to DC power supply applications.

Key Specifications

Part Number	GR-15E007DJ
V _{DSS} , min.	150V
I _{DS} , Pulse (25°C, TPULSE = 300 μs)	109A
R _{DS(ON)} , typ. @V _{GS} =6V	7.3mΩ
Q _G , typ.	7.1nC

Features

- 150 V enhancement mode power transistor
- High operating frequency
- R_{DS(on)} = Typ. 7.3mΩ
- RoHS compliant
- Zero QRR.

Applications

- Switch Mode Power Supplies (SMPS)
- DC-DC Converters
- Fast Battery Charging
- Appliance Motor Drives

GR-15E007DJ, RQFN-5x6-8L

Drain	5, 6, 7, 8
Gate	4
Source	1, 2, 3

1. Electrical Characteristics

➤ **Table 1 Absolute maximum ratings**

Symbol	Parameter	Value	Unit
V _{DSS}	Drain-source voltage	150	V
V _{(TR)DSS}	Transient drain to source voltage ^a	180	V
V _{GSS}	Gate- source voltage	-6V ~ +6V	V
I _D	Drain current (continuous) at T _C = 25°C operation	35	A
	Drain current (continuous) at T _C = 100°C operation	24	A
I _{D,Pulse}	Pulsed drain current (pulse width: 300μs, V _{gs} =5V) ^b	109	A
T _J	Operating temperature	-40 to +150	°C
T _S	Storage temperature	-40 to +150	°C
MSL	Moisture sensitivity level	MSL3	

- a. In off-state, spike duty cycle D<0.01, spike duration <1μs
- b. Defined by product design and characterization. Value is not tested to full current in production

➤ **Table 2 Thermal Characteristics**

Symbol	Parameter	Value	Unit
R _{θJC_Top}	Thermal resistance junction-case, Top	0.65	°C/W
R _{θJC_Bot}	Thermal resistance junction-case, Bottom	0.50	°C/W
R _{θJA}	Thermal resistance junction-ambient	60	°C/W

- a. Tested in package DFN-5x6.

➤ **Table 3 Electrical Characteristics** ($T_{CASE} = 25\text{ °C}$ unless otherwise stated)

Symbol	Parameter	Conditions	Values			Unit
			min.	typ.	max.	
V_{DSS}	Drain-source voltage	$V_{GS} = 0V, I_D = 250\mu A$	150	-	-	V
$V_{GS(th)}$	Gate threshold voltage	$V_{DS} = V_{GS}, I_D = 1mA$	0.8	1.1	1.5	V
$R_{DS(on)}$	Drain-source on-resistance	$V_{GS} = 6V, I_D = 20A$	-	7.3	9.5	mΩ
I_{DSS}	Drain-source leakage current	$V_{DS} = 120V, V_{GS} = 0V$	-	5	400	uA
I_{GSS}	Gate-to-Source Forward Leakage current	$V_{GS} = +5V, T_J = 25\text{ °C}$	-	0.05	10.0	mA
	Gate-to-Source Forward Leakage current	$V_{GS} = +5V, T_J = 125\text{ °C}$	-	0.60	18.0	mA
	Gate-to-Source Reverse Leakage current	$V_{GS} = -4V, T_J = 25\text{ °C}$	-	0.035	1.05	mA
C_{ISS}	Input capacitance	$V_{DS} = 75V, V_{GS} = 0V$	-	608	-	pF
C_{OSS}	Output capacitance		-	295	-	
C_{RSS}	Reverse transfer capacitance		-	10.5	-	
Q_G	Gate charge	$V_{DS} = 75V, V_{GS} = 5V, I_D = 20A$	-	7.1	-	nC
Q_{GS}	Gate-source charge	$V_{DS} = 75V, I_D = 20A$	-	2.6	-	
Q_{GD}	Gate-drain charge		-	1.5	-	
Q_{OSS}	Output charge	$V_{DS} = 75V, V_{GS} = 0V$	-	37.9	-	
Q_{RR}	Source-Drain Recovery Charge	-	-	0	-	

2. Typical Characteristic Curves

Fig 1. On-Region Characteristics

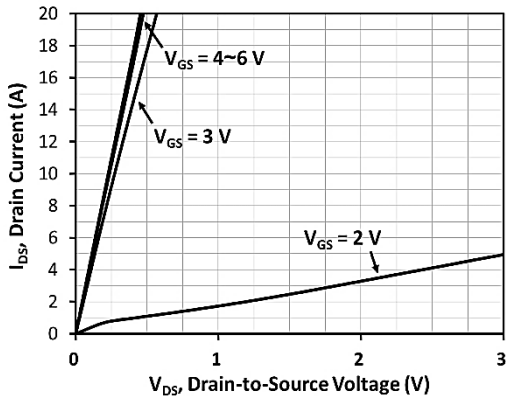

Fig 2. On-Resistance vs Drain Current and Temperature

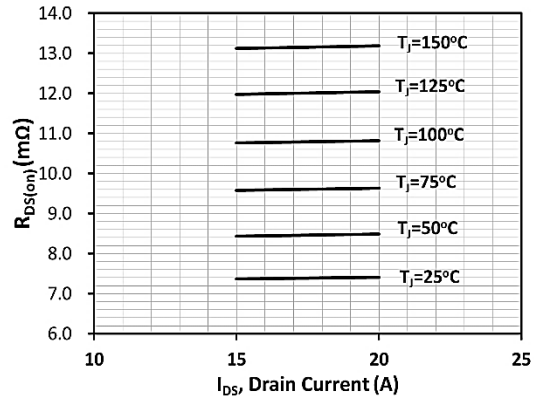

Fig 3. On-Resistance with Drain Current

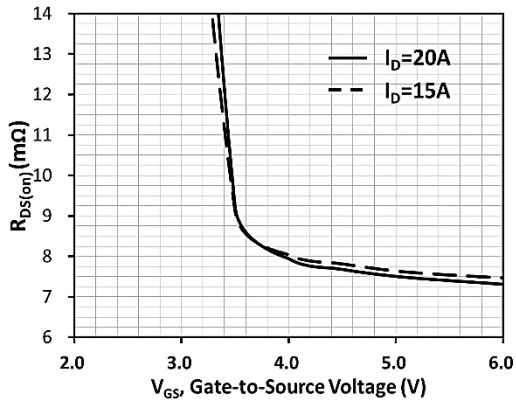

Fig 4. On-Resistance Variation with Temperature

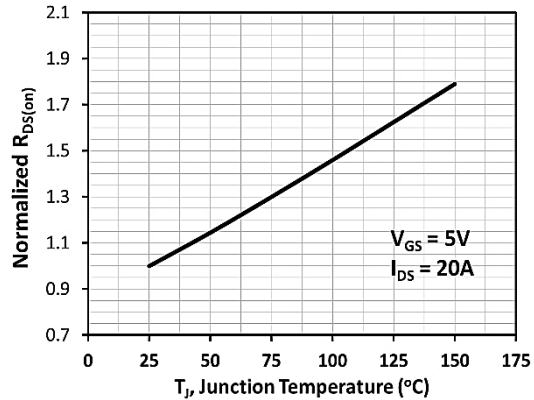

Fig 5. Threshold Voltage with Temperature

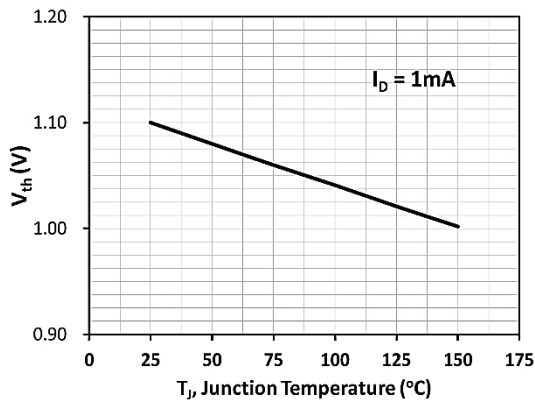

Fig 6. Capacitance Characteristics

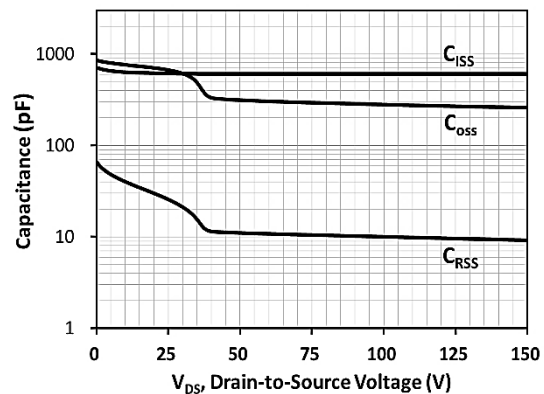

Fig 7. Gate Charge Characteristics, Qg

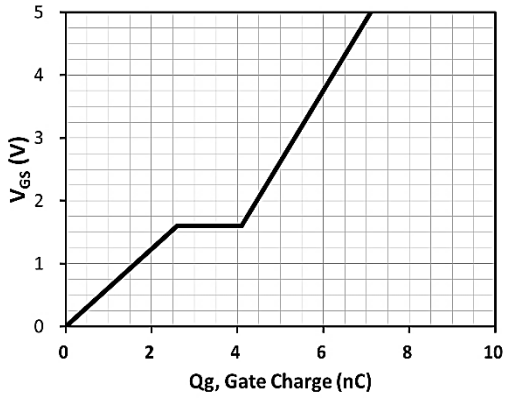
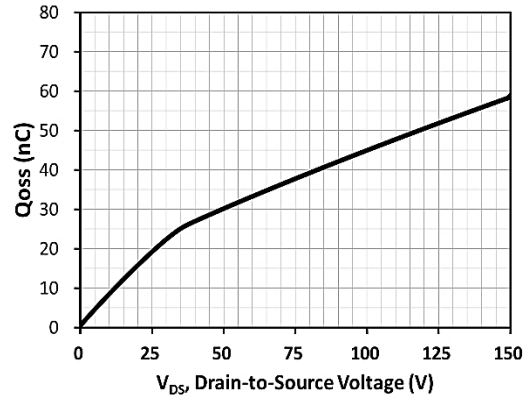
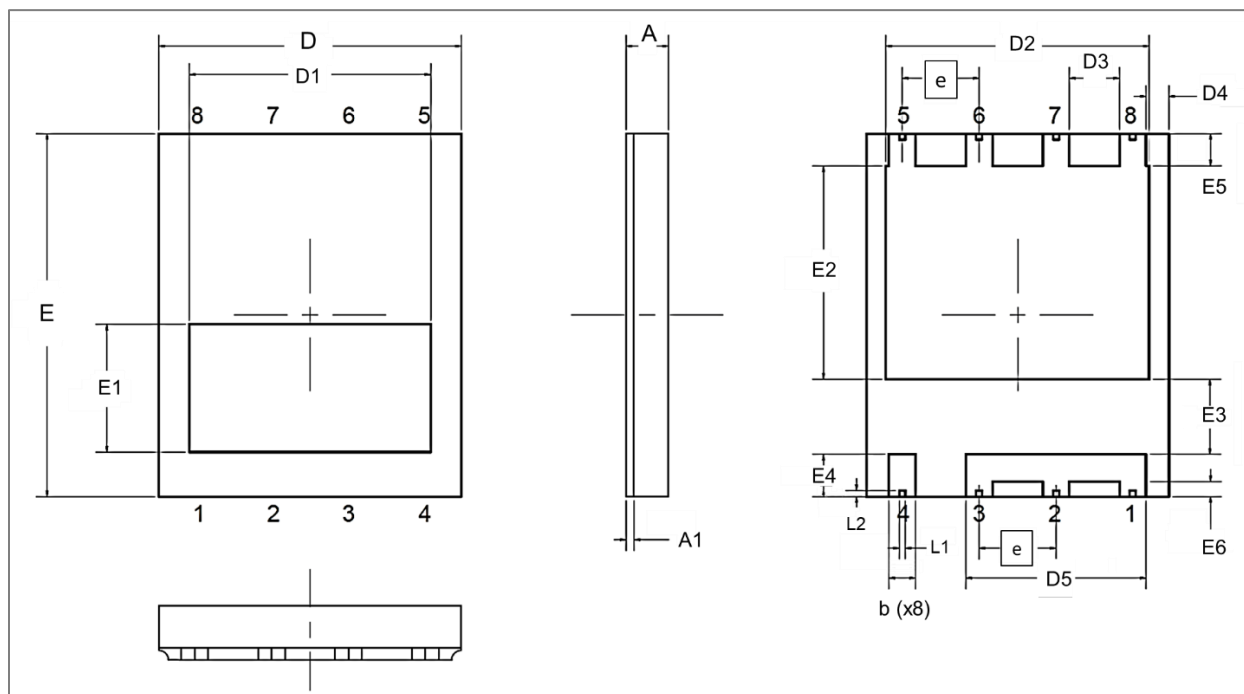

Fig 8. Capacitance Characteristics, Qoss



3. Package Outline Dimensions



➤ Table 4 Dimension of GR-RQFN-5x6-8L

SYMBOL	DIMENSION (IN MM)			SYMBOL	DIMENSION (IN MM)		
	MIN.	NOM.	MAX.		MIN.	NOM.	MAX.
A	---	---	0.70	D5	2.88	2.98	3.08
A1	0.13			E1	2.112 REF		
A2	0.42	0.45	0.48	E2	3.43	3.53	3.63
D	4.90	5.00	5.10	E3	1.14	1.24	1.34
E	2.90	6.00	3.10	E4	0.60	0.70	0.80
e	1.270 BSC			E5	0.43	0.53	0.63
b	0.34	0.44	0.54	E6	0.15	0.25	0.35
D1	3.994 REF			L1	0.05	0.10	0.20
D2	4.25	4.35	4.45	L2	0.05	0.10	0.20
D3	0.73	0.83	0.93				
D4	0.275	0.375	0.475				

4. Recommended PCB footprint

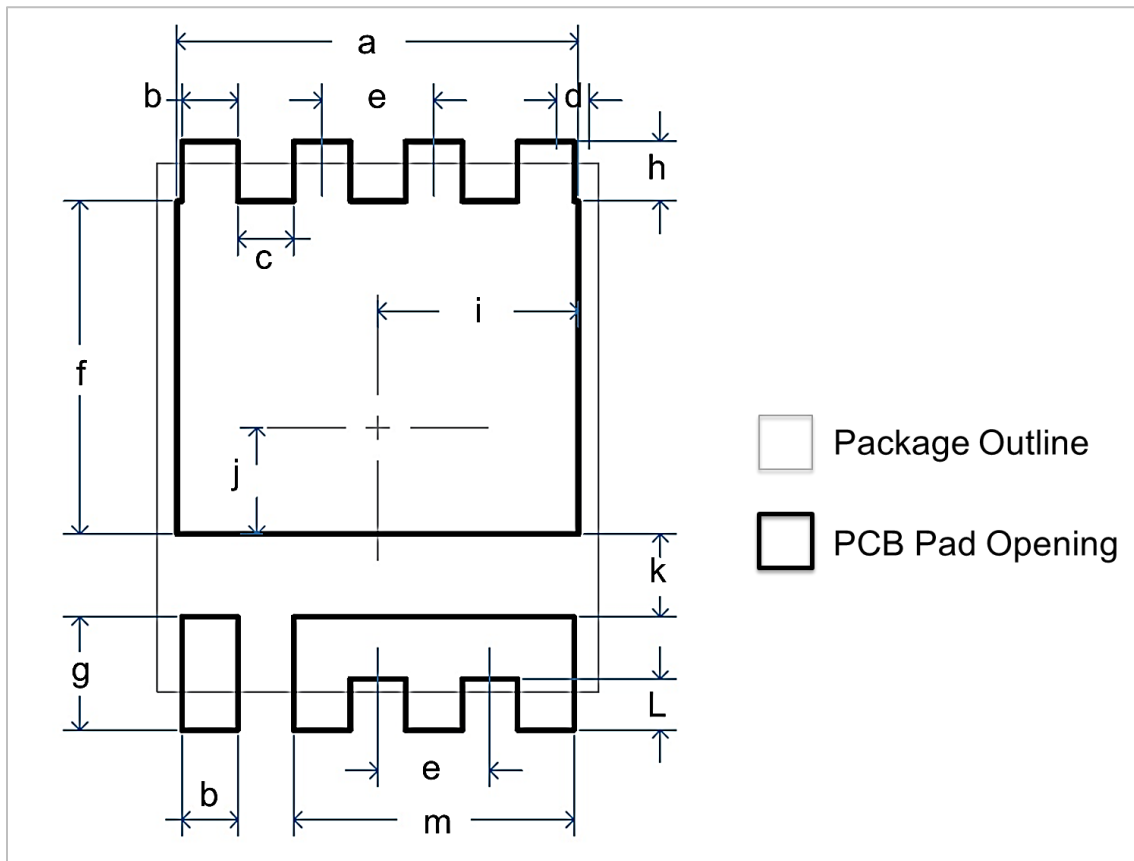

➤ **Table 5 PCB Footprint Dimension**

SYMBOL	DIMENSION	SYMBOL	DIMENSION
a	4.550	h	0.680
b	0.640	i	2.275
c	0.630	j	1.210
d	0.375	k	0.940
e	1.270	L	0.580
f	3.780	m	3.180
g	1.280	-	-

Notes:
 (1) All dimensions are in mm.
 (2) Drawing is not to Scale.

5. Tape & Reel Information

13" Reel, Carrier Tape W=12mm

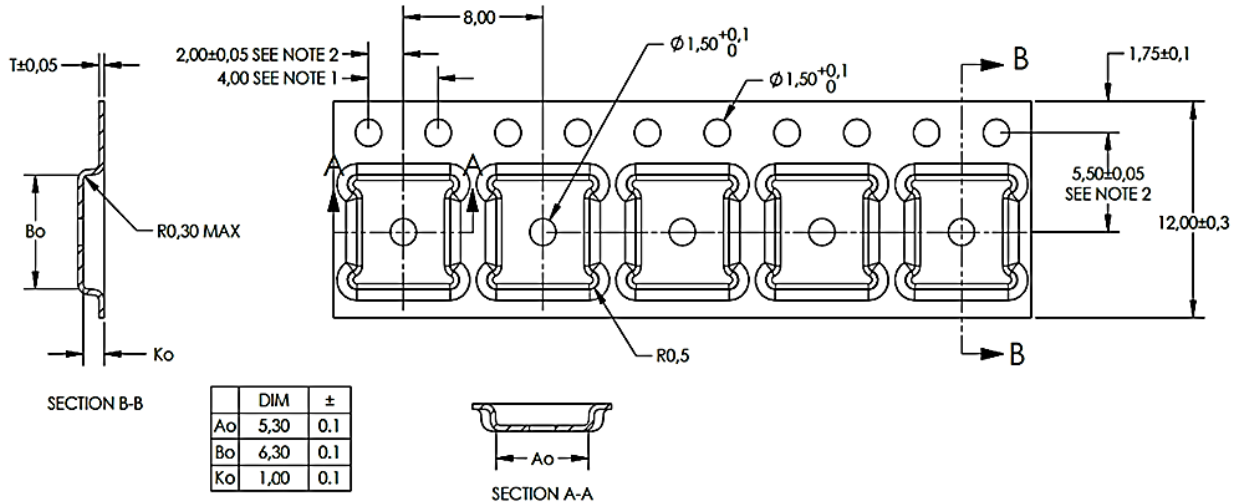

Unit: mm

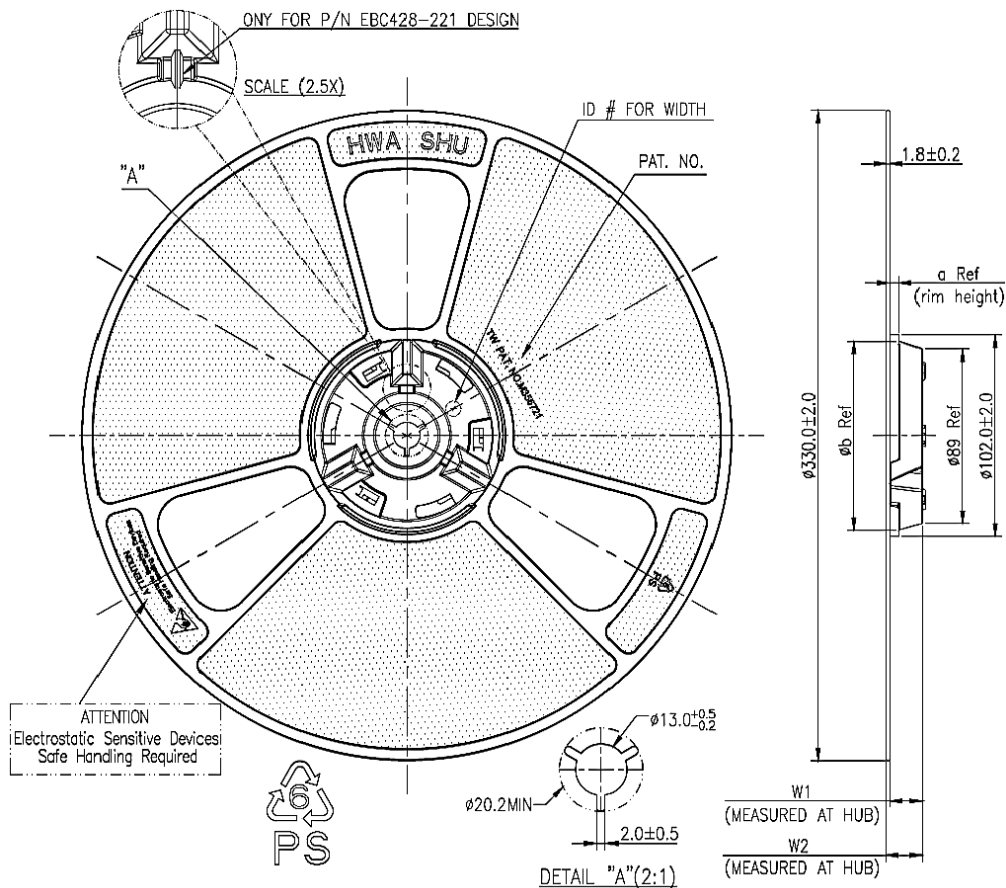

6. Change Log

Version	Date	Description
0.1	March 28, 2025	Initial version
0.2	October 22, 2025	Revised electrical characteristic curves.
0.3	Apr 16, 2026	Electrical characteristics revised.

DISCLAIMER

Except for the written expressed warranties, MGT does not implicitly, by assumption or whatever else, warrant, undertake, promise any other warranty or guaranty for any MGT product. All information and technical specifications made available by MGT are for guidance only and we reserve the right to change or modify them without prior notice. Unless expressly stated in writing by MGT, we reject any guarantees, obligations, or warranties. All MGT products with the technical specifications described are suitable for use in certain applications. Operating, production, storage and environmental conditions can have a massive influence on the parameters mentioned in the data sheets, which cause the performance to vary over time. It is subject to the user's duty of care to design and validate his products in such a way that appropriate measures are taken, such as protective circuits or redundant systems to ensure the safety standards required in the application. MGT components are not designed or rated for *use in life support, rescue, safety critical, military, or aerospace applications where failure or malfunction could result in property or environmental damage, serious injury or death*. In the aforementioned cases, please contact us before using MGT products. In principle, we reserve all rights and MGT's general terms and conditions apply. You can find them on our website www.mgt.co.com